

Flange X

Ordering code
T171X

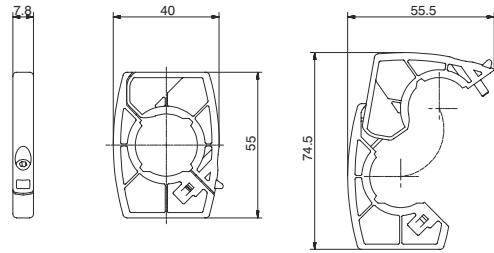

Weight 12 gr.
Example : T171X : Size 1 coupling flange
- Enables the quick connection of two functions

Flange Y

Ordering code
T171Y

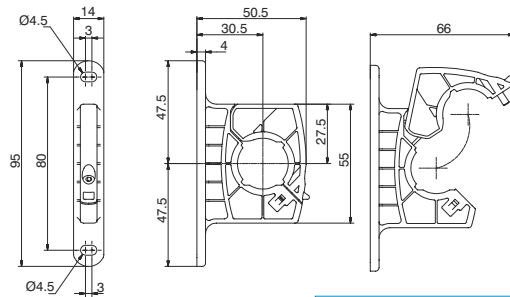
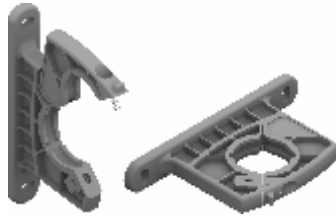

Weight 18 gr.
Example : T171Y : Size 1 coupling flange with mounting holes
- Used to couple together two elements and to panel mount them.
- Used to panel mount one single element.

Single unit panel mounting dimensions

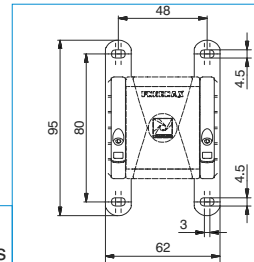

Fixing bracket

Ordering code
17150

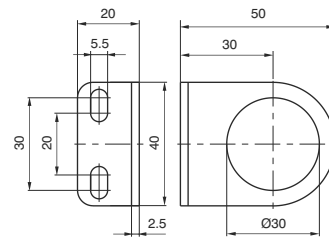

Weight 32 gr.
- Allows for regulators and filter regulators to be panel mounted.

Pressure gauge

Ordering code
17070
VERSION
A = Dial Ø40
B = Dial Ø50
SCALE
A = Scale 0-4 bar
B = Scale 0-6 bar
C = Scale 0-12 bar

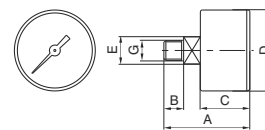

DIMENSIONS							
CODE	A	B	C	D	E	G	Weight gr.
17070A	44	10	26	41	14	1/8"	60
17070B	45	10	27	49	14	1/8"	80

Flange X

Ordering code
T172X

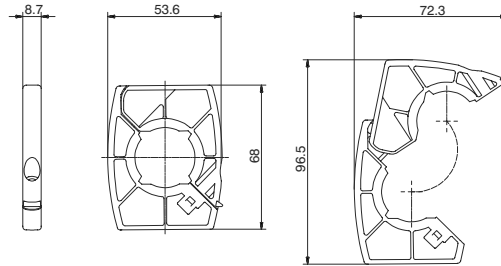

Weight 21 gr.
Example : T172X : Size 2 coupling flange
- Enables the quick connection of two functions.

Flange Y

Ordering code
T172Y

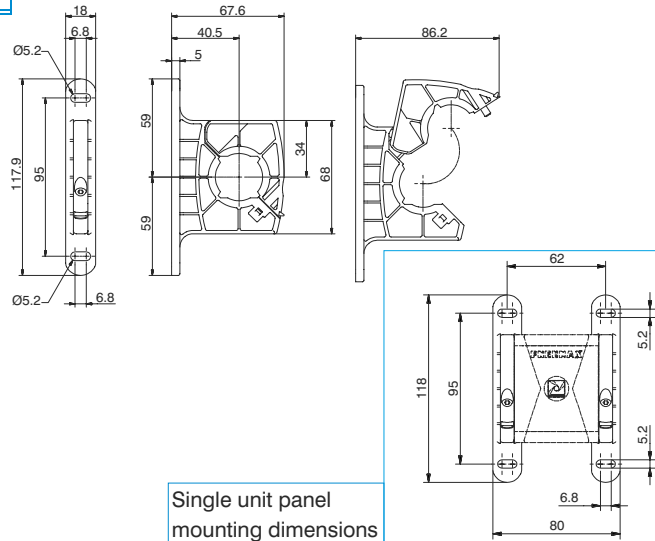
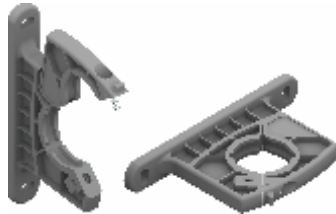

Weight 33 gr.
Example : T172Y : Size 2 coupling flange with mounting holes
- Used to couple together two elements and to panel mount them.
- Used to panel mount one single element.

Single unit panel mounting dimensions

Fixing bracket

Ordering code
T17250

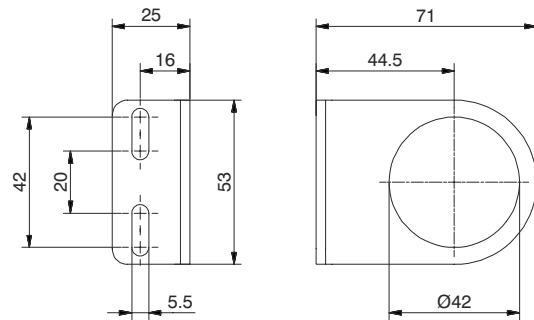

Weight 71 gr.
- Allows for regulators and filter regulators to be panel mounted.

Pressure gauge

Ordering code
17070
VERSION
V A = Dial Ø40
B = Dial Ø50
SCALE
S A = Scale 0-4 bar
B = Scale 0-6 bar
C = Scale 0-12 bar

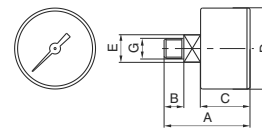

DIMENSIONS							
CODE	A	B	C	D	E	G	Weight gr.
17070A	44	10	26	41	14	1/8"	60
17070B	45	10	27	49	14	1/8"	80

3

Flange X

Ordering code
T173X

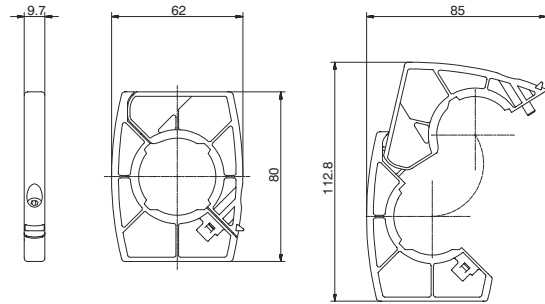

Weight 35 gr.
Example : T173X : Size 3 coupling flange
- Enables the quick connection of two functions.

Flange Y

Ordering code
T173Y

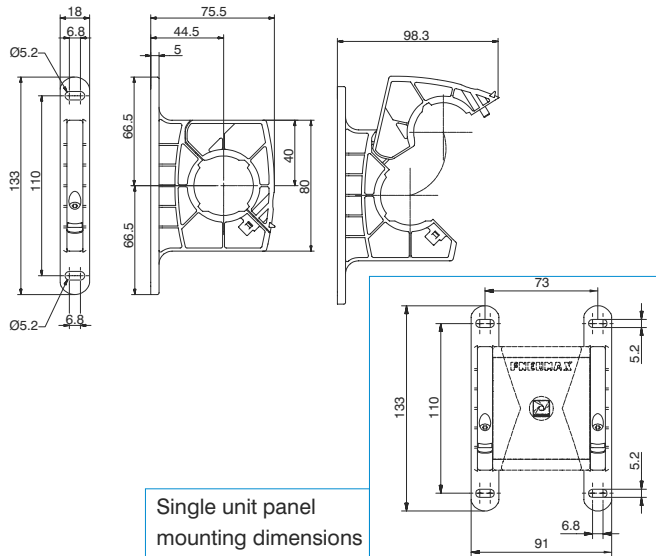
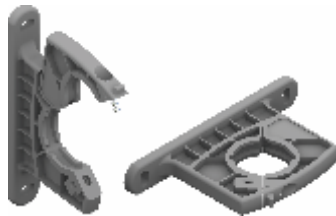

Weight 48 gr.
Example : T173Y : Size 3 coupling flange with mounting holes
- Used to couple together two elements and to panel mount them.
- Used to panel mount one single element.

Single unit panel mounting dimensions

Fixing bracket

Ordering code
T17250

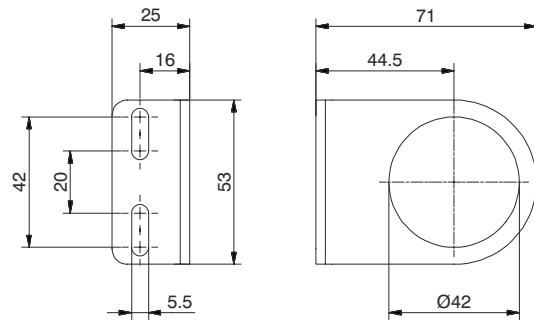

Weight 71 gr.
- Allows for regulators and filter regulators to be panel mounted.

Pressure gauge

Ordering code
17070
VERSION
A = Dial Ø40
B = Dial Ø50
SCALE
A = Scale 0-4 bar
B = Scale 0-6 bar
C = Scale 0-12 bar

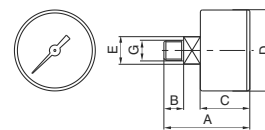

DIMENSIONS							
CODE	A	B	C	D	E	G	Weight gr.
17070A	44	10	26	41	14	1/8"	60
17070B	45	10	27	49	14	1/8"	80

Flange X

Ordering code

T174X

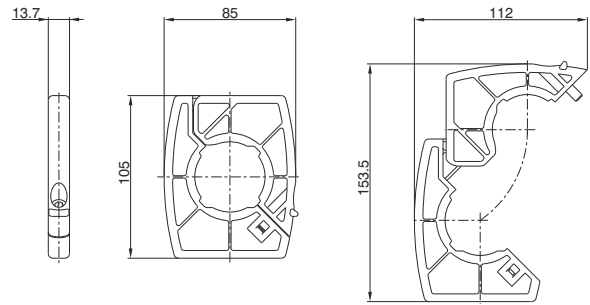

Weight 90 gr.
Example : T174X : Size 4 coupling flange
- Enables the quick connection of two functions.

Flange Y

Ordering code

T174Y

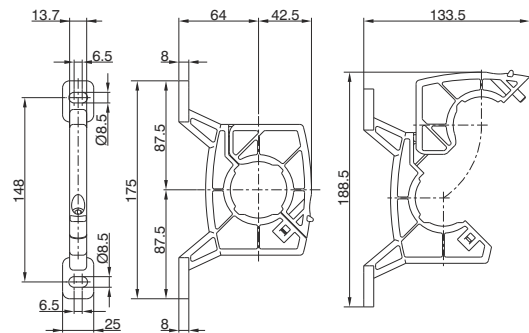

Weight 120 gr.
Example : T174Y : Size 4 coupling flange with mounting holes
- Used to couple together two elements and to panel mount them.
- Used to panel mount one single element.

Pressure gauge

Ordering code

17070

VERSION	
	A = Dial Ø40
	B = Dial Ø50
SCALE	
	A = Scale 0-4 bar
	B = Scale 0-6 bar
	C = Scale 0-12 bar

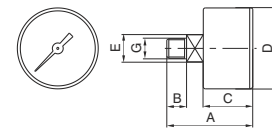

DIMENSIONS							
CODE	A	B	C	D	E	G	Weight gr.
17070A	44	10	26	41	14	1/8"	60
17070B	45	10	27	49	14	1/8"	80