





Servo-assisted 2/2-way diaphragm valve

- Servo-assisted diaphragm valve with nominal diameter of up to DN 40
- Spring coupled diaphragm opens without differential pressure
- Damped design for low noise
- High flow rate with compact design
- Energy-saving double coil technology with Kick and Drop variant



Product variants described in the data sheet may differ from the product presentation and description.

Can be combined with

	Type 2518 Cable plug, form A according to DIN EN 175301 - 803	▶
	Type 2513 Cable plug, form A according to DIN EN 175301 - 803	▶
	Type 1087 Timer, form A according to DIN EN 175301 - 803	▶

Type description

The 6213 EV valve is a servo-assisted diaphragm valve of the S.EV series. The diaphragm spring coupling supports the opening process of the valve. In its standard version, the valve is suitable for use in liquids. A minimum differential pressure is required for complete opening. A special version (HP00) which opens the valve without differential pressure is available for gas and vacuum applications. Various diaphragm material combinations are available depending on the application. The range of housings includes brass, stainless steel and gunmetal. Dezincification-resistant brass is available for other markets. To reduce power consumption in operation, coils with Kick and Drop electronics assembly (double coil technology) are available.

1. General technical data



Product properties	
Dimensions	Detailed information can be found in chapter "5. Dimensions" on page 6.
Material	
Seal	NBR, FKM, EPDM
Body	Brass acc. to DIN EN 50930-6 Stainless steel 1.4408 Gunmetal (external thread) DN 10...DN 20
Coil	Polyamide, epoxy (insulation class H)
Inner part of valve	Brass body: Brass, stainless steel and PPS Stainless steel body: Stainless steel and PPS Gunmetal body: Stainless steel and PPS (external thread) DN 10...DN 20
Orifice	Standard: DN 10...DN 40 HP00: DN 13...DN 20
Circuit function	Detailed information can be found in chapter "2. Circuit functions" on page 4.
Performance data	
Duty cycle	100 % continuous rating; KD coil max. rating 6 circuit switches/minute
Switching time^{1.)} AC/DC	
DN 10...DN 13	Opening: 10...100 ms Closing: 100...200 ms
DN 20	Opening: 200...300 ms Closing: 400...700 ms
DN 25...DN 40	Opening: 300...400 ms Closing: 800...1400 ms
Electrical data	
Operating voltage	Standard: 024/DC, 024/50, 230/50, 110/50, 120/60 HP00: 024/DC, 24 V (50...60 Hz), 230 V (50...60 Hz)
Power consumption	Depending on orifice and coil size For detailed information, see "6. Performance specifications" on page 11
Voltage tolerance	± 10 %
Medium data	
Operating medium	
NBR	Neutral fluids, water, hydraulic oil, oil without additives
FKM	Per-solutions, hot oils with additives
EPDM	Oil and fat-free fluids and gases
Medium temperature	
NBR	- 10 °C...+80 °C
FKM	0 °C...+90 °C with polyamide coil 0 °C...+120 °C with epoxy coil
EPDM	-30 °C...+90 °C with polyamide coil -30 °C...+100 °C with epoxy coil
EPDM with drinking water approval according to UBA	Application range of cold and hot water up to +60 °C
Viscosity	Max. 21 mm ² /s
Process/Port connection & communication	
Electrical connection	Tag connector acc. to DIN EN 175 301 - 803 form A (see "8.4. Ordering chart accessories" on page 20)
Approvals and certificates	
Degree of protection	IP65 IP65 with cable plug Type 2518 ▶ 4X NEMA with stainless steel version and cable plug Type 2509 ▶
Environment and installation	
Installation	As required, preferably with actuator upright
Ambient temperature	Max. +55 °C

1.) Measurement at 6 bar and +20 °C at the valve outlet, opening: pressure build-up 0...90 %, closing: pressure reduction 100...10 %

2. Circuit functions

Circuit functions	Description
	Type: A, solenoid valve 2/2-way Servo-controlled Normally closed

3. Approvals

Approvals	Description
 	Explosion-proof approvals ATEX: EPS 18 ATEX 1232 X II 2G Ex mb IIC T4 Gb II 2D Ex mb IIIC T130 °C Db II 2G Ex eb mb IIC T4 Gb II 2D Ex mb tb IIIC T130 °C Db IECEx: IECEx EPS 18.0110 X Ex mb IIC T4 Gb Ex mb IIIC T130 °C Db Ex eb mb IIC T4 Gb Ex mb tb IIIC T130 °C Db

4.2. Material specifications

Note:

The sectional view shown corresponds to the standard version nominal diameter 20. For other versions and nominal diameters, the sectional view varies.

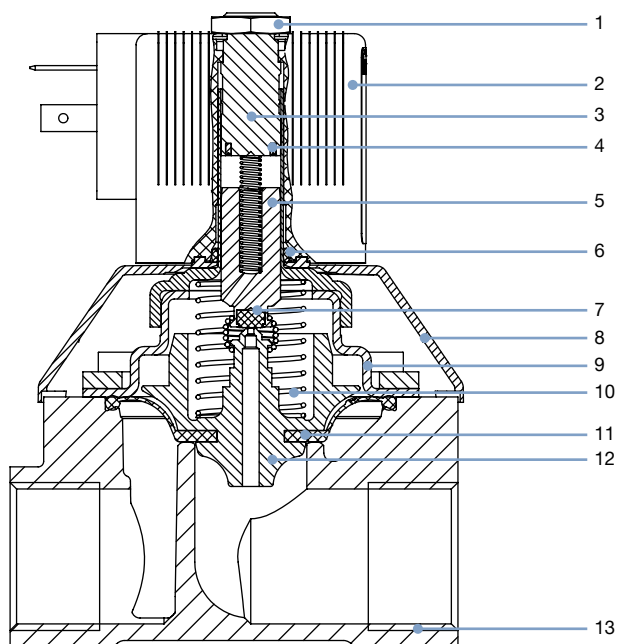

No.	Element	Material
1	Locknut	Steel (surface thick-film passivated acc. to RoHS) Stainless steel 1.4305, PTFE coated
2	Coil	Polyamide or Epoxy
3	Stopper	Stainless steel 1.4113
4	Shading ring (only AC version)	with brass body: Copper (Cu) with stainless steel body: Silver (Ag)
5	Magnetic core	Stainless steel 1.4113
6	O-Ring	FKM
7	Plunger seal	NBR, FKM, EPDM
8	Bonnet	PA6
9	Cover	DN 10...DN 25: Stainless steel 1.4301 DN 40: Brass, stainless steel 1.4408
10	Spring	Stainless steel 1.4310
11	Diaphragm	NBR, FKM, EPDM
12	Diaphragm support	PPSGF40 in combination with brass and accordingly stainless steel parts
13	Valve body	Brass, stainless steel 1.4408 Gunmetal with external thread

5. Dimensions

5.1. Standard version with brass and stainless steel body

Note:

- Dimensions in mm
- The dimensions F1 and G1 apply to G-threads
- The dimensions F2 and G2 apply to NPT-threads
- The dimensions F3 and G3 apply to Rc-threads

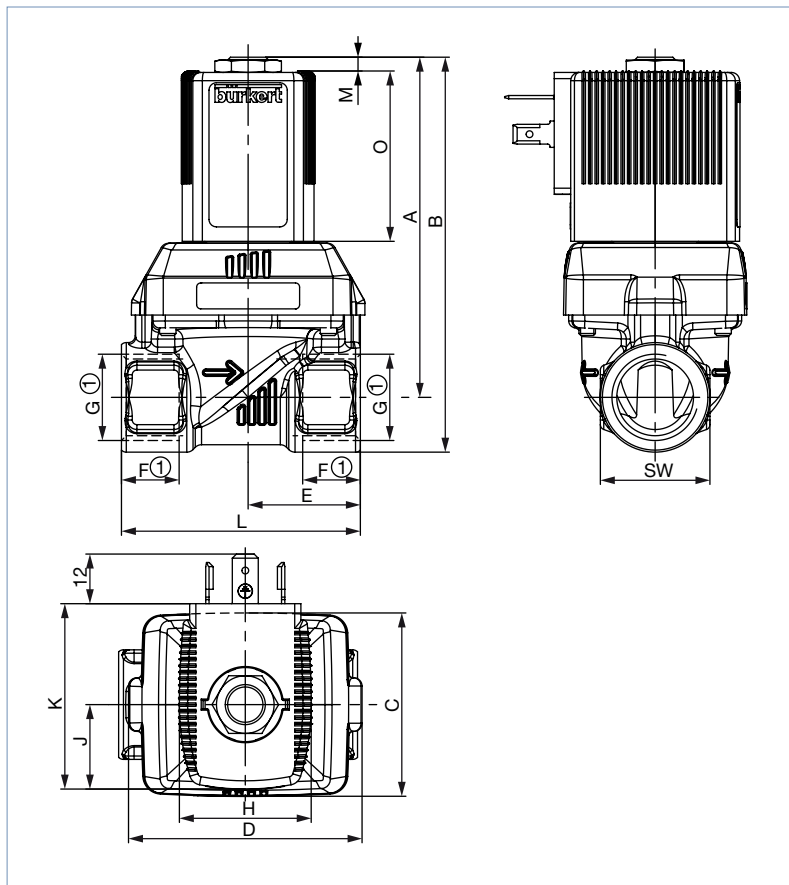

DN	A	B	C	D	E	Connection thread						L	SW	Coil size
						G		NPT		Rc				
						(MS/VA)	F1	G1	F2	G2	F3			
10	71.1	82.1	36	46	22	12	G ¼	10.0	NPT ¼	–	–	50	22	5 and 6
10 ¹⁾	73.1	86.6			24.5	12	G ⅜	10.3	NPT ⅜	10.1	Rc ⅜	50	27	
10 ²⁾						14	G ½	13.7	NPT ½	13.2	Rc ½	55		
13 ¹⁾	82.6	95.9	44.5	56.7	27.25	14	G ½	13.7	NPT ½	13.2	Rc ½	58	27	5 and 6
13 ²⁾					32.5							65		
13	84.6	100.6			32.5	16	G ¾	14	NPT ¾	14.5	Rc ¾	65	32	
20	97.1	113.1	65	76.6	37	16	G ¾	14	NPT ¾	14.5	Rc ¾	80	32	5 and 6
20	99.6	120.1			37.5	18	G 1	16.8	NPT 1	16.8	Rc 1	80	41	
20														
13 ¹⁾	109.3	122.8	44.5	56	27.25	14	G ½	13.7	NPT ½	13.2	Rc ½	58	27	K and L
13 ²⁾					32.5							65		
13	111.3	127.3			32.5	16	G ¾	14	NPT ¾	14.5	Rc ¾	65	32	
20	123.9	139.9	65	76.6	37	16	G ¾	14	NPT ¾	14.5	Rc ¾	80	32	K and L
20	126.4	146.9			37.5	18	G 1	16.8	NPT 1	16.8	Rc 1	80	41	
20														
25	143.4	163.4	77	88	46	18	G 1	16.8	NPT 1	16.8	Rc 1	95	41	K and L
25	148.3	173.3			46	20	G 1¼	17.3	NPT 1¼	19.1	Rc 1¼	95	50	

DN	A	B	C	D	E	Connection thread						L	SW	Coil size
						G		NPT		Rc				
						(MS/VA)	F1	G1	F2	G2	F3			
40 ^{1.)}	153.9	178.9	104.5	117	61	20	G 1¼	17.3	NPT 1¼	19.1	Rc 1¼	126	50	K and L
40	159.4	189.4			61	22	G 1½	17.3	NPT 1½	19.1	Rc 1½	126	60	
40	165.4	200.4			64	24	G 2	17.6	NPT 2	23.4	Rc 2	132	70	

1.) Only in threaded brass connection

2.) Only in threaded stainless steel connection

5.2. Gunmetal version with external thread

Note:

Dimensions in mm

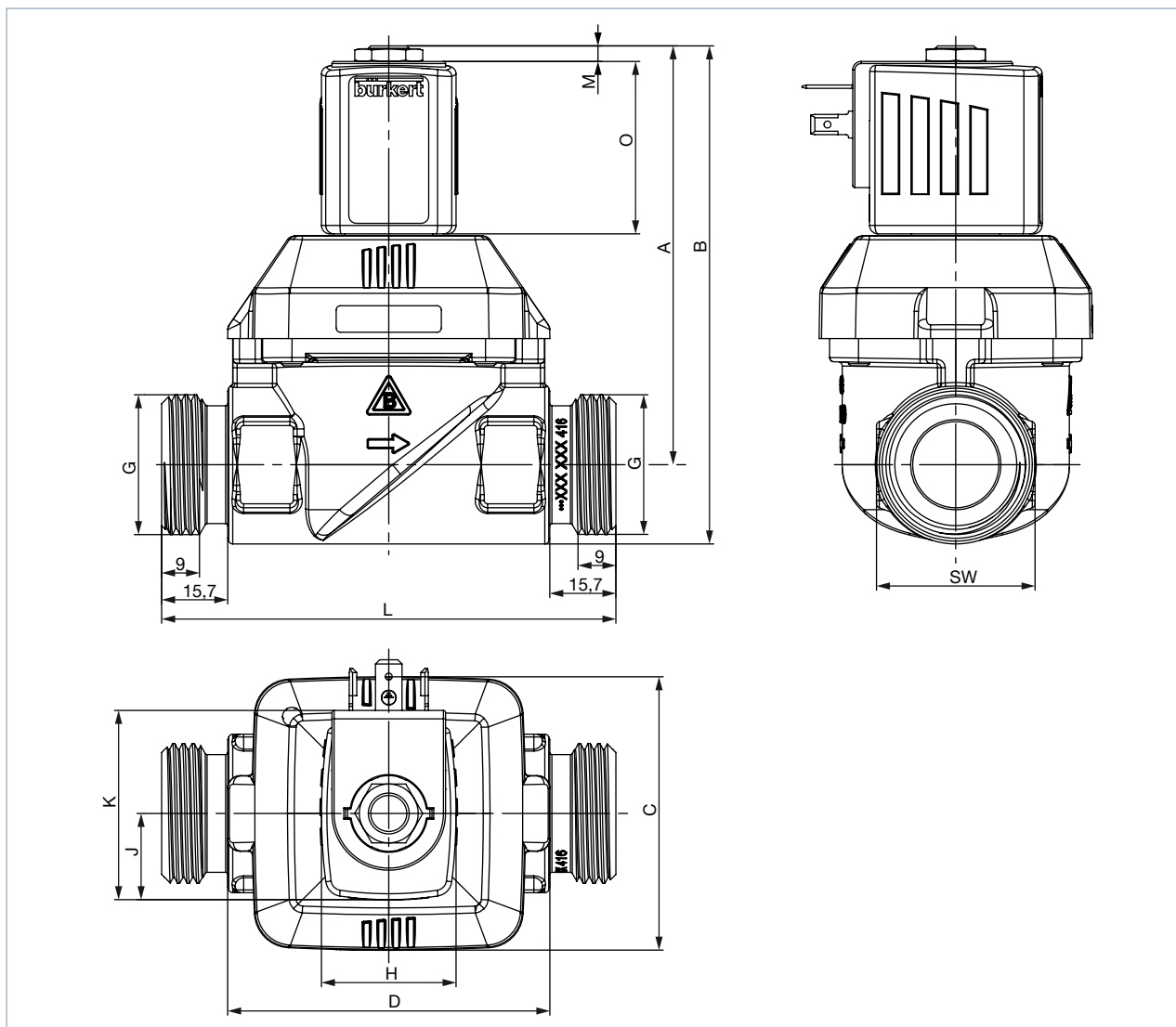

DN	A	B	C	D	G	L	SW	Coil size
10	73.1	86.1	36	46	G ½	80	26	5 and 6
13	84.6	100.6	44.5	56.7	G ¾	89	32	5 and 6
20	99.6	118.5	65	76.6	G 1	108	37.7	5 and 6
13	104.3	120.3	44.5	56.7	G ¾	89	32	K and L
20	119.3	139.8	36	76.6	G 1	108	37.7	K and L

5.3. Coil dimension

Note:

Dimensions in mm

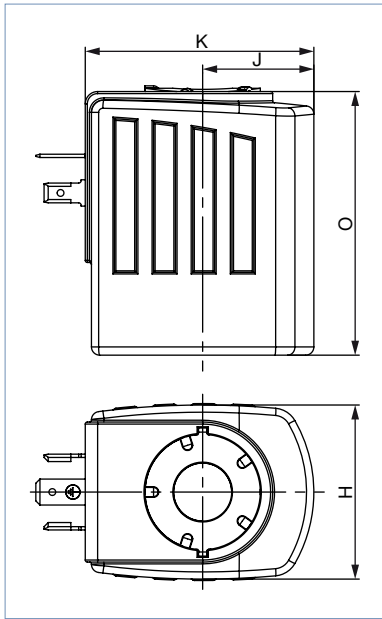

Coil size	H	J	K	O	M
5	32	20.5	45	41	3.4
6	40	23.5	51	41	3.4
K	42	27	55.5	64	7
L	65	37.5	72	64	7

5.4. ATEX/IECEEx version

Note:

Coil with terminal box and cable gland or coil with cable connection on request.

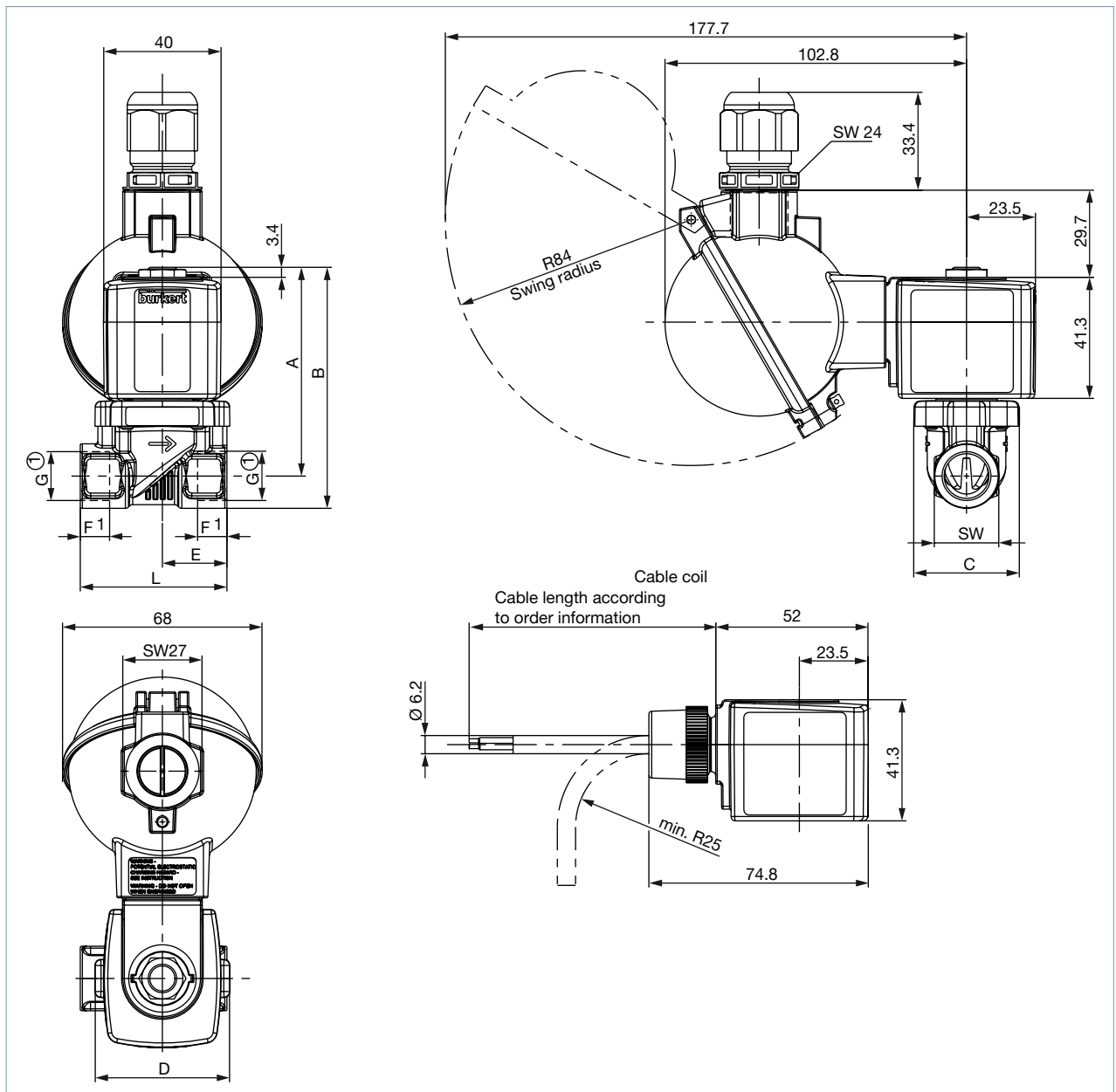

DN	A	B	C	D	E	G		NPT		Rc		L	SW
						F1	G1	F2	G 2	F3	G 3		
10	71.2	82.2	36	45.6	22	12	G ¼	10	NPT ¼	-	-	50	22
	73.2	86.7			24.5	14	G ½	13.7	NPT ½	13.2	Rc ½		27
13	82.7	96	44.5	56.7	27.25	14	G ½	13.7	NPT ½	13.2	Rc ½	55	27
	84.7	100.7			32.5	16	G ¾	14	NPT ¾	14.5	Rc ¾	58	32
					65							80	
20	97.2	113.2	65	76.6	37	16	G ½	14	NPT ¾	14.5	Rc ¾	80	41
	99.7	120.2			37.5	18	G 1	16.8	NPT 1	16.8	Rc 1		

5.5. ATEX version with terminal box (HP00 version)

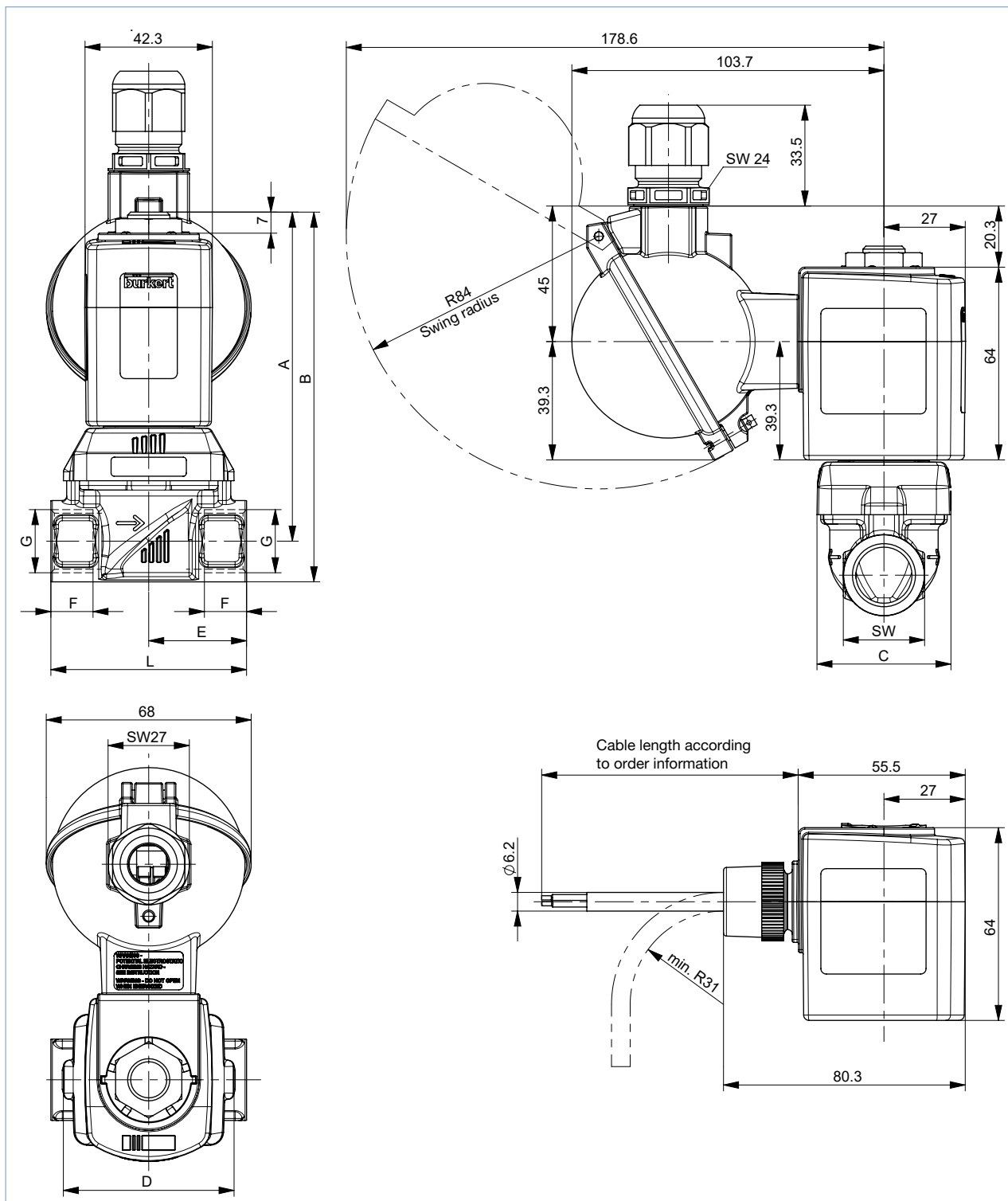

DN	A	B	C	D	E	F	G	L	SW
13 ¹⁾	109.3	122.8	44.5	56.7	27.25	14	G 1/2	58	27
13 ²⁾					32.5			65	
20	116.8	132.8	65	76.6	37	16	G 3/4	80	32

6. Performance specifications

6.1. Power consumption

Nominal size	Coil size		AC			DC		KD coil AC/DC ATEX/IECEx ²⁾		
			Inrush	Hold	Cooling capacity	Heat performance	AC		AC/DC	
							Cooling capacity ^{1.)} Inrush (500 ms)	Cooling capacity ^{1.)} Hold		Heat performance Hold
[mm]	[mm]	SG	[VA]	[VA]	[W]	[W]	[W]	[W]	[W]	[W]
10	32	5	34	14	8	–	–	–	–	–
10	40	6	–	–	10	11	10	–	–	–
13	32	5	36	14	8	–	–	–	–	–
13	40	6	–	–	10	11	10	–	–	–
13	42	K	125	37	16	21	16	44	6.5	5.5
20	32	5	38	14	8	–	–	–	–	–
20	40	6	–	–	10	11	10	–	–	–
20	42	K	140	37	16	21	16	44	6.5	5.5
25	42	K	150	37	16	–	–	85	8.5	7
25	65	L	–	–	–	28	21	–	–	–
40	42	K	190	37	16	–	–	85	8.5	7
40	65	L	–	–	–	28	21	–	–	–

1.) Cold performance refers to a coil temperature of 20 °C



2.) Kick and Drop coil (KD coil): Coil with energy-saving Kick and Drop electronics in double coil technology

7. Product accessories

7.1. Cable glands for ATEX/IECEx terminal box

Note:

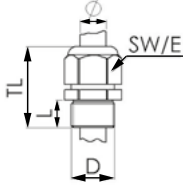
- A cable gland in polyamide version is included in the delivery. A nickel-plated brass version can be ordered at a surcharge, see [“8.4. Ordering chart accessories” on page 20.](#)
- This special tool is not supplied with the valve, see [“8.3. Ordering chart” on page 13.](#)

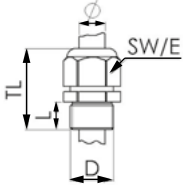
Description	Ex approvals		Dimensions											
	Certification	Identification												
Ex cable gland, Brass, nickel-plated, 6...13 mm 	PTB 04 ATEX 1112 X, IECEx PTB 13.0027X	II 2 G Ex e IIC Gb, II 2 D Ex tb IIIC Db IP68		<table border="1"> <tr> <td>TL</td> <td>29...37 mm</td> </tr> <tr> <td>L</td> <td>6 mm</td> </tr> <tr> <td>D</td> <td>20 mm</td> </tr> <tr> <td>SW</td> <td>24 mm</td> </tr> <tr> <td>E</td> <td>27 mm</td> </tr> </table>	TL	29...37 mm	L	6 mm	D	20 mm	SW	24 mm	E	27 mm
TL	29...37 mm													
L	6 mm													
D	20 mm													
SW	24 mm													
E	27 mm													
Ex cable gland, Polyamide, 7...13 mm 	PTB 13 ATEX 1015 X, IECEx PTB 13.0034X	II 2 G Ex e IIC Gb, II 2 D Ex tb IIIC Db IP68		<table border="1"> <tr> <td>TL</td> <td>36...45 mm</td> </tr> <tr> <td>L</td> <td>10 mm</td> </tr> <tr> <td>D</td> <td>20 mm</td> </tr> <tr> <td>SW</td> <td>24 mm</td> </tr> <tr> <td>E</td> <td>28 mm</td> </tr> </table>	TL	36...45 mm	L	10 mm	D	20 mm	SW	24 mm	E	28 mm
TL	36...45 mm													
L	10 mm													
D	20 mm													
SW	24 mm													
E	28 mm													

7.2. Special tool to turn the junction box

Note:

- This special tool is not supplied with the valve, see “8.3. Ordering chart” on page 13.
- This special tool can only be used with ATEX AC10 coils.

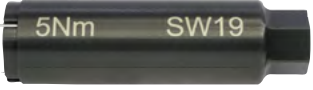
Description	Components of the set
Set SC02-AC10 	<ul style="list-style-type: none">• Special wrench• Service manual

7.3. Kick and Drop coil

Detailed information can be found in data sheet ACKD, see **Type 6213**











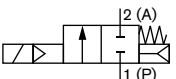





















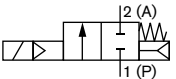















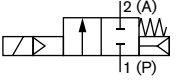



































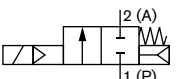











►.

8.3. Ordering chart

Standard version with brass body

Note:

- Please note that the cable plug has to be ordered separately, see “8.4. Ordering chart accessories” on page 20 or separate datasheet **Type 2518** ▶.
- Further versions on request

Circuit function	Port connection	Orifice	K _v value	Pressure	Weight ⁴⁾	Article no. per voltage/frequency			
		[mm]	water ^{1) 2)} [m ³ /h]	range ³⁾ [bar]	[kg]	024/DC	024/50	230/50	
Seal material NBR, polyamide coil, medium temperature -10...+80 °C									
A, solenoid valve 2/2-way Servo-controlled Normally closed 	G ¼	10	1.3	0...10	0.3 (0.5)	221674 	221675 	221677 	
	G ¾	10	1.9	0...10	0.3 (0.5)	221598 	221599 	221601 	
	G ½	10	1.9	0...10	0.4 (0.5)	221606 	221607 	221609 	
	G ½	13	3.6	0...10	0.4 (0.5)	221602 	221603 	221605 	
	G ¾	13	3.6	0...10	0.5 (0.6)	221618 	221619 	221621 	
	G ¾	20	8.3	0...10	0.7 (0.8)	221630 	221631 	221633 	
	G 1	20	8.3	0...10	0.9 (1.0)	221634 	221635 	221637 	
Seal material NBR, epoxy coil, medium temperature -10...+80 °C									
A, solenoid valve 2/2-way Servo-controlled Normally closed 	G 1	25	11	0...10	1.6 (2.2)	227533 	221725 	221728 	
	G 1¼	25	11	0...10	1.7 (2.3)	227534 	221729 	221732 	
	G 1¼	40	23	0...10	2.9 (3.4)	270903 	270895 	270899 	
	G 1½	40	30	0...10	3.2 (3.7)	227539 	221750 	221753 	
	G 2	40	30	0...10	3.4 (3.9)	227541 	221754 	221757 	
Seal material FKM, epoxy coil, medium temperature 0...+120 °C									
A, solenoid valve 2/2-way Servo-controlled Normally closed 	G ¼	10	1.3	0...10	0.3 (0.5)	221678 	221679 	221681 	
	G ¾	10	1.9	0...10	0.3 (0.5)	221610 	221611 	221613 	
	G ½	10	1.9	0...10	0.4 (0.5)	221614 	221615 	221617 	
	G ½	13	3.6	0...10	0.4 (0.5)	221622 	221623 	221625 	
	G ¾	13	3.6	0...10	0.5 (0.6)	221626 	221627 	221629 	
	G ¾	20	8.3	0...10	0.7 (0.8)	221638 	221639 	221641 	
	G 1	20	8.3	0...10	0.9 (1.0)	221642 	221643 	221645 	
	G 1	25	11	0...10	1.6 (2.2)	227537 	221733 	221736 	
	G 1¼	25	11	0...10	1.7 (2.3)	227538 	221737 	221740 	
	G 1¼	40	23	0...10	2.9 (3.4)	270905 	270906 	270908 	
	G 1½	40	30	0...10	3.2 (3.7)	227544 	227724 	227726 	
	G 2	40	30	0...10	3.4 (3.9)	227545 	227728 	227730 	
	Seal material EPDM, polyamide coil, medium temperature -30...+90 °C								
	A, solenoid valve 2/2-way Servo-controlled Normally closed 	G ¼	10	1.3	0...10	0.3 (0.4)	221670 	221671 	221673 
G ¾		10	1.9	0...10	0.3 (0.4)	221646 	221647 	221649 	
G ½		10	1.9	0...10	0.4 (0.5)	221650 	221651 	221653 	
G ½		13	3.6	0...10	0.4 (0.5)	221654 	221655 	221657 	
G ¾		13	3.6	0...10	0.5 (0.6)	221658 	221659 	221661 	
G ¾		20	8.3	0...10	0.7 (0.8)	221662 	221663 	221665 	
G 1		20	8.3	0...10	0.9 (1.0)	221666 	221667 	221669 	

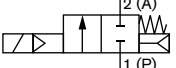
Circuit function	Port connection	Orifice	K _v value water ^{1.) 2.)}	Pressure range ^{3.)}	Weight ^{4.)}	Article no. per voltage/frequency [V/Hz]		
		[mm]	[m ³ /h]	[bar]	[kg]	024/DC	024/50	230/50
Seal material EPDM, epoxy coil, medium temperature -30...+100 °C								
A, solenoid valve 2/2-way Servo-controlled Normally closed 	G 1	25	11	0...10	1.6 (2.2)	227535	221717	221720
	G 1¼	25	11	0...10	1.7 (2.3)	227536	221721	221724
	G 1¼	40	23	0...10	2.9 (3.4)	270904	270890	270894
	G 1½	40	30	0...10	3.2 (3.7)	227542	221741	221745
	G 2	40	30	0...10	3.4 (3.9)	227543	221746	221749

1.) Measurement at 1 bar^{3.)} and +20 °C at the valve inlet and free outlet

2.) A pressure difference of 0.5 bar is required to open the full cross-section.

3.) Pressure data: Overpressure to atmospheric pressure

4.) The values in brackets regarding the weight apply to the DC version.

5.) For gas and vacuum applications, a minimum pressure of 0.5 bar is required for DC versions. Alternatively, HP00 versions can be used.

Standard version with drinking water approval according to UBA

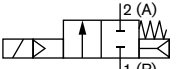
Circuit function	Port connection	Orifice	K _v value water ^{1.) 2.)}	Pressure range ^{3.)}	Weight ^{4.)}	Article no. per voltage/frequency [V/Hz]		
		[mm]	[m ³ /h]	[bar]	[kg]	024/DC	024/50	230/50
Seal material EPDM, epoxy coil, medium temperature -30...+90 °C								
A, solenoid valve 2/2-way Servo-controlled Normally closed 	G ¼	10	1.3	0...10	0.3 (0.4)	20056269	20056273	20056275
	G ¾	10	1.9	0...10	0.3 (0.4)	20056276	239270	252227
	G ½	10	1.9	0...10	0.4 (0.5)	20056277	20056280	20056282
	G ½	13	3.6	0...10	0.4 (0.5)	20056292	20056285	255143
	G ¾	13	3.6	0...10	0.5 (0.6)	221658	20056293	252111
	G ¾	20	8.3	0...10	0.7 (0.8)	20056294	221663	252399
	G 1	20	8.3	0...10	0.9 (1.0)	20056296	20056297	252401

1.) Measurement at 1 bar^{3.)} and +20 °C at the valve inlet and free outlet

2.) A pressure difference of 0.5 bar is required to open the full cross-section.

3.) Pressure data: Overpressure to atmospheric pressure











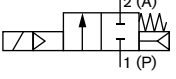







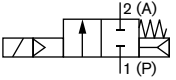

4.) The values in brackets regarding the weight apply to the DC version.

5.) For gas and vacuum applications, a minimum pressure of 0.5 bar is required for DC versions. Alternatively, HP00 versions can be used.

HP00 version with brass body

Note:

Preferably used for gas and vacuum applications as well as for liquids with increased flow and tightness requirements at low differential pressure.









Circuit function	Port connection	Orifice	K _v value	Pressure	Weight	Article no. per voltage/frequency		
		[mm]	water ^{1.)} [m ³ /h]	range ^{2.)} [bar]		[kg]	024/DC	024/50...60
Brass body, seal material FKM, epoxy coil, medium temperature 0...+120 °C								
A, solenoid valve 2/2-way Servo-controlled Normally closed 	G ½	13	3.6	0...10	0.8	221706 	221705 	231574 
	G ¾	20	8.3	0...10	1.3	221712 	221711 	221713 
	G 1	20	8.3	0...10	1.4	221715 	221714 	221716 
Brass body, seal material EPDM, epoxy coil, medium temperature -30...+100 °C								
A, solenoid valve 2/2-way Servo-controlled Normally closed 	G ½	13	3.6	0...10	0.8	221694 	221693 	221695 
	G ¾	20	8.3	0...10	1.3	208422 	221699 	189592 
	G 1	20	8.3	0...10	1.4	221703 	221702 	221704 

1.) Measurement at 1 bar^{2.)} and +20 °C at the valve inlet and free outlet

2.) Pressure data: Overpressure to atmospheric pressure

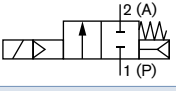
HP00 version: Explosion proofed ATEX/IECEx version with 3 m cable**Note:**

- The Kick and Drop coil (AC/DC) features integrated electronics for short-term power increase and decrease in double coil technology.
- The maximum fluid temperature must not in any case exceed the permissible temperature class (T4 135 °C, T5 100 °C, T6 85 °C), minus 5 K.
- Kick and Drop coil max. 6 switching operations/minute
- Detailed information on the approvals, see chapter **“3. Approvals”** on page 4.

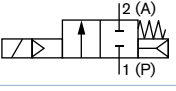
Circuit function	Port connection	Orifice	K _v value water ^{1.)}	Pressure range ^{2.)}	Weight	Article no. per voltage/frequency [V/Hz]	
		[mm]	[m ³ /h]	[bar]	[kg]	024/UC	230...240/UC
Brass body, seal material EPDM, KD coil, medium temperature -30...+100 °C^{3.)}							
A, solenoid valve 2/2-way Servo-controlled Normally closed	G ½	13	3.6	0...10	0.8	20051200 	20051201 
	G ¾	20	8.3	0...10	1.3	20051202 	20051203 
							
Stainless steel body, seal material FKM, KD coil, medium temperature 0...+120 °C							
A, solenoid valve 2/2-way Servo-controlled Normally closed	G ½	13	3.6	0...10	0.8	20031389 	20051206 
	G ¾	20	8.3	0...10	1.3	20046809 	20051207 
							

1.) Measurement at 1 bar^{2.)} and +20 °C at the valve inlet and free outlet

2.) Pressure data: Overpressure to atmospheric pressure

HP00 version: Explosion proofed ATEX/IECEx version with terminal box

Note:











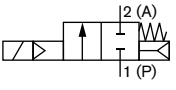











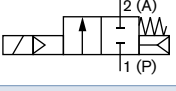











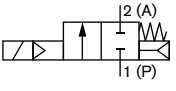























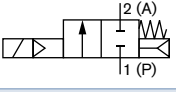











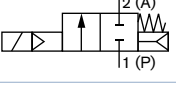

- The Kick and Drop coil (AC/DC) features integrated electronics for short-term power increase and decrease in double coil technology.
- The maximum fluid temperature must not in any case exceed the permissible temperature class (T4 135 °C, T5 100 °C, T6 85 °C), minus 5 K.
- Detailed information on the approvals, see chapter **“3. Approvals” on page 4**

Circuit function	Port connection	Orifice	K _v value water ^{1.)}	Pressure range ^{2.)}	Weight	Article no. per voltage/frequency [V/Hz]	
		[mm]	[m ³ /h]	[bar]	[kg]	024/UC	230...240/UC
Brass body, seal material EPDM, KD coil, medium temperature -30...+100 °C							
A, solenoid valve 2/2-way Servo-controlled Normally closed 	G ½	13	3.6	0...10	0.8	20051208	20051210
	G ¾	20	8.3	0...10	1.3	20051211	20051212
Stainless steel body, seal material FKM, KD coil, medium temperature 0...+120 °C							
A, solenoid valve 2/2-way Servo-controlled Normally closed 	G ½	13	3.6	0...10	0.8	20051213	20051214
	G ¾	20	8.3	0...10	1.3	20018095	20051216

1.) Measurement at 1 bar^{2.)} and +20 °C at the valve inlet and free outlet

2.) Pressure data: Overpressure to atmospheric pressure

Standard version with stainless steel body

Circuit function	Port connection	Orifice	K _v value	Pressure	Weight ⁴⁾ [kg]	Article no. per voltage/frequency [V/Hz]		
		[mm]	water ^{1) 2)} [m ³ /h]	range ³⁾ [bar]		024/DC ⁵⁾	024/50	230/50
Seal material NBR, polyamide coil, medium temperature -10...+80 °C								
A, solenoid valve 2/2-way Servo-controlled Normally closed 	G 3/8	10	1.9	0...10	0.3 (0.4)	222150 	222151 	222152 
	G 1/2	13	3.6	0...10	0.4 (0.5)	222156 	222157 	222158 
	G 3/4	20	8.3	0...10	0.7 (0.8)	222168 	222169 	222170 
	G 1	20	8.3	0...10	0.9 (1.0)	222171 	222172 	222173 
Seal material NBR, epoxy coil, medium temperature -10...+80 °C								
A, solenoid valve 2/2-way Servo-controlled Normally closed 	G 1	25	11	0...10	1.6 (2.2)	227546 	228429 	222193 
	G 1 1/4	25	11	0...10	1.7 (2.3)	227547 	228432 	222197 
	G 1 1/2	40	30	0...10	3.2 (3.7)	227552 	228435 	222201 
	G 2	40	30	0...10	3.4 (3.9)	227554 	228438 	222205 
Seal material FKM, epoxy coil, medium temperature 0...+120 °C								
A, solenoid valve 2/2-way Servo-controlled Normally closed 	G 3/8	10	1.9	0...10	0.3 (0.4)	221758 	221759 	221761 
	G 1/2	13	3.6	0...10	0.4 (0.5)	221762 	221763 	221765 
	G 3/4	20	8.3	0...10	0.7 (0.8)	222122 	222123 	222125 
	G 1	20	8.3	0...10	0.9 (1.0)	222126 	222127 	222129 
	G 1	25	11	0...10	1.6 (2.2)	227550 	228430 	222143 
	G 1 1/4	25	11	0...10	1.7 (2.3)	227551 	228433 	222145 
	G 1 1/2	40	30	0...10	3.2 (3.7)	227557 	228436 	222147 
	G 2	40	30	0...10	3.4 (3.9)	227558 	228439 	222149 
Seal material EPDM, polyamide coil, medium temperature -30...+90 °C								
A, solenoid valve 2/2-way Servo-controlled Normally closed 	G 3/8	10	1.9	0...10	0.3 (0.4)	222153 	222154 	222155 
	G 1/2	13	3.6	0...10	0.4 (0.5)	222159 	222160 	222161 
	G 3/4	20	8.3	0...10	0.7 (0.8)	222174 	222175 	222176 
	G 1	20	8.3	0...10	0.9 (1.0)	222177 	222178 	222179 
Seal material EPDM, epoxy coil, medium temperature -30...+100 °C								
A, solenoid valve 2/2-way Servo-controlled Normally closed 	G 1	25	11	0...10	1.6 (2.2)	227548 	228431 	222195 
	G 1 1/4	25	11	0...10	1.7 (2.3)	227549 	228434 	222199 
	G 1 1/2	40	30	0...10	3.2 (3.7)	227555 	228437 	222203 
	G 2	40	30	0...10	3.4 (3.9)	227556 	228440 	222207 

1.) Measurement at 1 bar³⁾ and +20 °C at the valve inlet and free outlet

2.) A pressure difference of 0.5 bar is required to open the full cross-section.

3.) Pressure data: Overpressure to atmospheric pressure











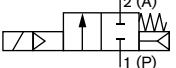







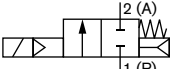

4.) The values in brackets regarding the weight apply to the DC version.

5.) For gas and vacuum applications, a minimum pressure of 0.5 bar is required for DC versions. Alternatively, HP00 versions can be used.

HP00 version with stainless steel body

Note:









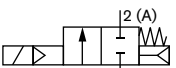

Preferably used for gas and vacuum applications as well as for liquids with increased flow and tightness requirements at low differential pressure.

Circuit function	Port connection	Orifice	K _v value water ^{1.)}	Pressure range ^{2.)}	Weight ^{3.)}	Article no. per voltage/frequency [V/Hz]		
		[mm]	[m ³ /h]	[bar]	[kg]	024/DC	024/50...60	230/50...60
Seal material FKM, epoxy coil, medium temperature 0...+120 °C								
A, solenoid valve 2/2-way Servo-controlled Normally closed 	G ½	13	3.6	0...10	0.8	208694 	220585 	205351 
	G ¾	20	8.3	0...10	1.3	222137 	222136 	222138 
	G 1	20	8.3	0...10	1.4	222140 	222139 	222141 
Seal material EPDM, epoxy coil, medium temperature -30...+100 °C								
A, solenoid valve 2/2-way Servo-controlled Normally closed 	G ½	13	3.6	0...10	0.8	213132 	222166 	220584 
	G ¾	20	8.3	0...10	1.3	222186 	222187 	222188 
	G 1	20	8.3	0...10	1.4	222189 	222190 	222191 

1.) Measurement at 1 bar^{2.)} and +20 °C at the valve inlet and free outlet

2.) Pressure data: Overpressure to atmospheric pressure

Gunmetal housing with external thread and drinking water approval according to UBA

Circuit function	Port connection	Orifice	K _v value water ^{1.) 2.)}	Pressure range ^{3.)}	Weight ^{4.)}	Article no. per voltage/frequency [V/Hz]		
		[mm]	[m ³ /h]	[bar]	[kg]	024/DC	024/50	230/50
						[V/Hz]	[V/Hz]	[V/Hz]
Seal material EPDM, epoxy coil, medium temperature. Application range of cold and hot water up to +60 °C								
A, solenoid valve 2/2-way Servo-controlled Normally closed 	G ½	10	1.9	0...10	0.4	311670 	311674 	311679 
	G ¾	13	3.6	0...10	0.6	311681 	311684 	311688 
	G 1	20	8.3	0...10	1.1	311691 	311693 	311696 

1.) Measurement at 1 bar^{3.)} and +20 °C at the valve inlet and free outlet

2.) A minimum differential pressure of 0.5 bar is required for full (100%) opening.

3.) Pressure data: Overpressure to atmospheric pressure

Further versions on request	
Process connection NPT, Rc, welded connection	Approval <ul style="list-style-type: none"> • Drinking water approval acc. to UBA assessment principles (PF23) • VDE Approval acc. to DIN EN 60730 (VDE0631) (PW01/PW02) • Watermark Licence (PF20) • UL (UL Listed) approval (MH10753) (PE95) • UR (UL Recognized) approval (PE94) • NEMA 250 Type 4X • WRAS approval (PD23) (DN 10, DN 13, DN 20) (PD23) • Safety shut-off valve for combustion facilities according to DIN EN ISO 23553-1 (PD22) • CSA Certification (PD01) • ATEX Cat. 3G/D (PX80/PX81)
Temperature <ul style="list-style-type: none"> • EPDM version up to +100 °C with epoxy coil (NA38) • FKM version up to +120 °C with epoxy coil (NA38) 	
Voltage Further Voltages available	
Material <ul style="list-style-type: none"> • Brass dezincification resistant (MZ) • Nickel-plated brass (5 µm) (AF43) • Gunmetal with external thread (DN 10, DN 13, DN 20) 	
Coil Kick and Drop version: Coil with energy-saving Kick and Drop electronics in double-coil technology (CZ05)	

8.4. Ordering chart accessories

Cable plug Type 2518, form A according to DIN EN 175301 - 803

Note:

For further versions see data sheet [Type 2518](#) ▶.

Cable plug	Dimensions	Version	Voltage	Article no.
		Without circuitry (AC/DC)	0...250 V AC/DC	314802
		With LED (AC/DC)	12...24 V AC/DC	314812
		With LED and varistor (AC/DC)	12...24 V AC/DC	314820
		With rectifier, LED and varistor	12...24 V AC/DC	314816

Cable glands for ATEX/IECEX terminal box

Note:

- A cable gland in polyamide version is included in the delivery. A nickel-plated brass version can be ordered at surcharge.
- For more information on Ex cable glands, see [“7.1. Cable glands for ATEX/IECEX terminal box” on page 11.](#)
- For more information on Special wrench see [“7.2. Special tool to turn the junction box” on page 12.](#)









Description	Article no.
Ex cable gland, brass, nickel-plated, 6...13 mm ¹⁾	773278
Ex cable gland, polyamide, 7...13 mm ¹⁾	773277
Set SC02-AC10: special wrench ²⁾ incl. service manual	293488

1.) Cable diameter

2.) Not included in the scope of delivery of the valve

Timer Type 1087, form A according to DIN EN 175301 - 803
Note:

 For more information on the timer, see data sheet **Type 1087** ▶.

Timer	Approval	Product code	Voltage range	Article no.
Analogue version 	–	1087-A-BCH-UC-28	10...30 V AC/DC	348828 
	–	1087-A-BDK-UC-28	24...240 V AC/DC	348829 
	cURus	1087-A-BCH-UC-28*PU01	10...30 V AC/DC	348906 
	cURus	1087-A-BDK-UC-28*PU01	24...240 V AC/DC	348907 
Digital version 	–	1087-A-BFW-UC-29	10...48 V AC/DC	348830 
	–	1087-A-BDX-UC-29	110...240 V AC/DC	348831 
	cURus	1087-A-BFW-UC-29*PU01	10...48 V AC/DC	348908 
	cURus	1087-A-BDX-UC-29*PU01	110...240 V AC/DC	348909 