



Lugged & Tapped Butterfly Valve – NBR Liner

- Fits Between Flanges
- Lever or Gearbox Operating Choices
- Fits Between PN10/16 1" - 6"
- Fits Between PN16 8" - 24"
- Epoxy Coated Ductile Iron Body
- Stainless Steel Disc
- ISO 5211 Mounting Pad

> Description

A general purpose Lugged and Tapped butterfly valve, suitable to fit between flanges 1" to 6" PN10/ PN16, 8" to 24" PN16 Flanges. Blue epoxy coated ductile iron body with a BUNA (NBR) liner. The valve is supplied with a notched (throttling) locking lever operator up to 12", with gearbox operation for 12" and above, however the valve can be fitted with a gearbox for all sizes. The valve has an ISO 5211 top works for direct mount of electric or pneumatic actuators. The valve complies with 97/23/CE (PED) Directive CE 1115

Can be fitted with Aluminium bronze disc.

> At a Glance

NBR (BUNA) Liner
 Temperature -10°C to 80°C
 1" to 6" to fit PN10, PN16.
 8" to 24" to fit PN16 Flanges.
 Ideal for End of Line Duty.



Description

A general purpose Lugged and Tapped butterfly valve fitted with a BUNA (NBR) liner options. Stainless steel disc as standard. Suitable to bolt between flanges. Notched Lever or Gearbox operated.
 PN10/16 1"-6". PN16 8"-24"



Beschreibung

Eine Allzweck-Scheibenklappe mit Lugged und Gewinde, die mit einer BUNA (NBR)-Auskleidungsoption ausgestattet ist. Edstahlscheibe serienmäßig. Zum Verschrauben zwischen Flanschen geeignet. Betrieb mit Rasthebel oder Getriebe.
 PN10/16 1"-6". PN16 8"-24"



Descripción

Una válvula de mariposa de uso general con orejetas y roscas equipada con opciones de revestimiento BUNA (NBR). Disco de acero inoxidable de serie. Adecuado para atornillar entre bridas. Operado por palanca con muescas o caja de cambios.
 PN10/16 1"-6". PN16 8"-24"



Description

Une vanne papillon à oreilles et taraudés à usage général équipée d'options de revêtement BUNA (NBR). Disque en acier inoxydable de série. Convient pour boulonner entre les brides. Levier cranté ou boîte de vitesses actionnée.
 PN10/16 1"-6". PN16 8"-24"

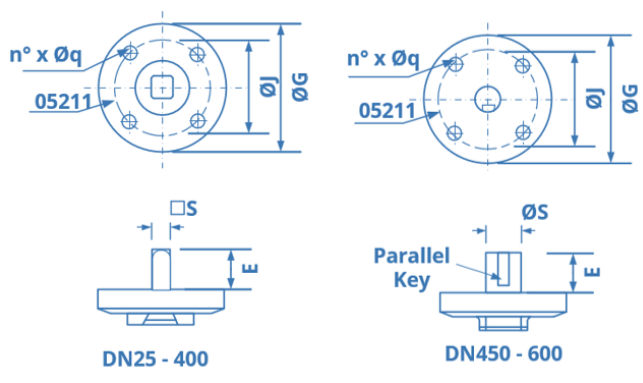
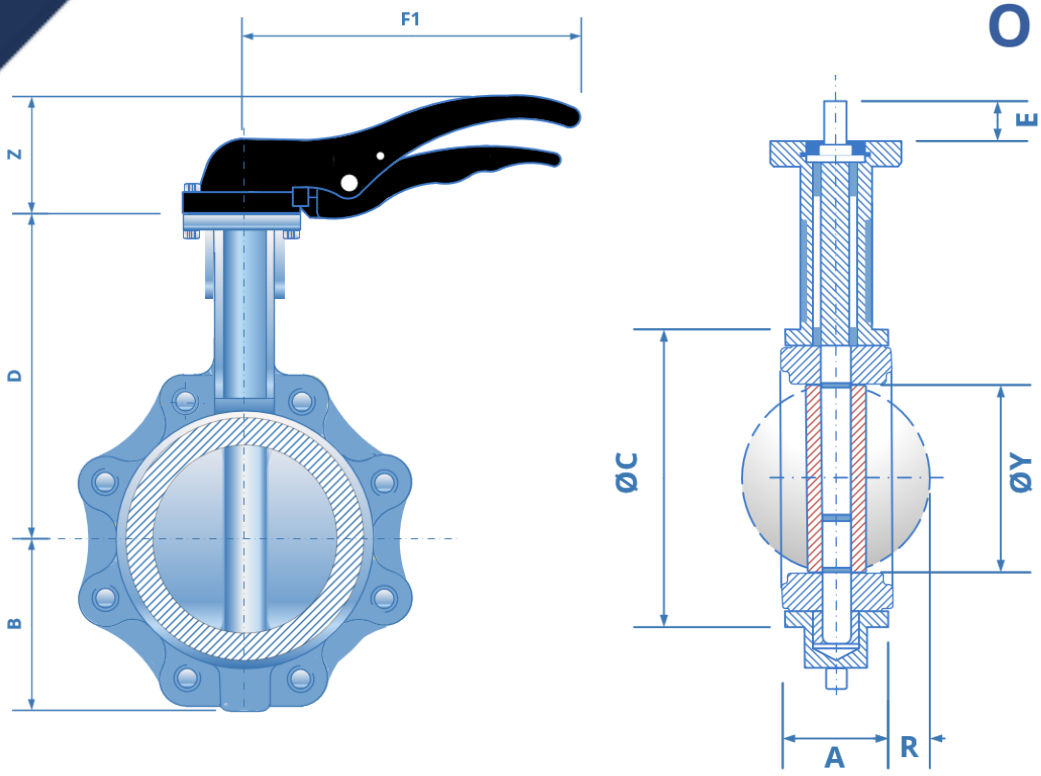

Drilling Dimensions					
Size	PN10			PN16	
	ØF	No x M	ØF	No x M	
1"	25	85	4 x 12	85	4 x 12
1 1/2"	40	110	4 x 16	110	4 x 16
2"	50	125	4 x 16	125	4 x 16
2 1/2"	65	145	4 x 16	145	4 x 16
3"	80	160	4 x 16	160	4 x 16
4"	100	180	8 x 16	180	8 x 16
5"	125	210	8 x 16	210	8 x 16
6"	150	240	8 x 20	240	8 x 16
8"	200	295	8 x 20	295	12 x 20
10"	250	350	12 x 20	355	12 x 24
12"	300	400	12 x 20	410	12 x 24
14"	350	460	16 x 20	470	16 x 24
16"	400	515	16 x 24	525	16 x 27
18"	450	565	20 x 24	585	20 x 27
20"	500	620	20 x 24	650	20 x 30
24"	550	725	20 x 27	770	20 x 33

Dimensions and Weights																
Size	A	B	ØC	D	R	Z	F1	ØY	KG	ISO	E	G	J	S	n x q	
1"	25	33	51	65	104		68	192	2.6	F05	32	65	50	7	4 x 7	
1 1/2"	40	33	63	82	116	5	50	170	27	2.3	F05	21	65	50	9	4 x 7
2"	50	43	62	89	126	5	50	170	31	3.2	F05	21	65	50	9	4 x 7
2 1/2"	65	46	69	102	136	9	50	170	45	4.1	F05	21	65	50	9	4 x 7
3"	80	46	90	118	150	17	69	206	65	5.4	F05	21	65	50	11	4 x 7
4"	100	52	106	150	170	26	69	206	90	6.7	F05	21	65	50	11	4 x 7
5"	125	56	119	174	180	34	90	285	110	9.6	F07	27	90	70	14	4 x 9
6"	150	56	131	205	200	50	90	285	146	10.8	F07	27	90	70	14	4 x 9
8"	200	60	166	260	230	71	72	400	194	21.1	F10	27	125	102	17	4 x 11
10"	250	68	202	318	266	91	72	530	241	32.7	F12	27	150	125	27	4 x 13
12"	300	78	235	376	292	112	-	-	291	41.2	F12	27	150	125	27	4 x 13
14"	350	78	257	406	335	128	-	-	324	79.3	F12	27	150	125	27	4 x 13
16"	400	102	292	471	360	144	-	-	379	122.6	F12	27	150	125	27	4 x 13
18"	450	114	318	539	422	163	-	-	428	154.8	F14	51	210	165	27	4 x 22
20"	500	127	355	594	480	182	-	-	475	228.3	F14	64	210	165	36	4 x 22
24"	550	154	444	695	562	219	-	-	573	308.6	F16	70	210	165	36	4 x 22

All information is sourced from our manufacturer's data and is intended for guidance only - Valves Online can accept no liability for changes, omissions or errors.

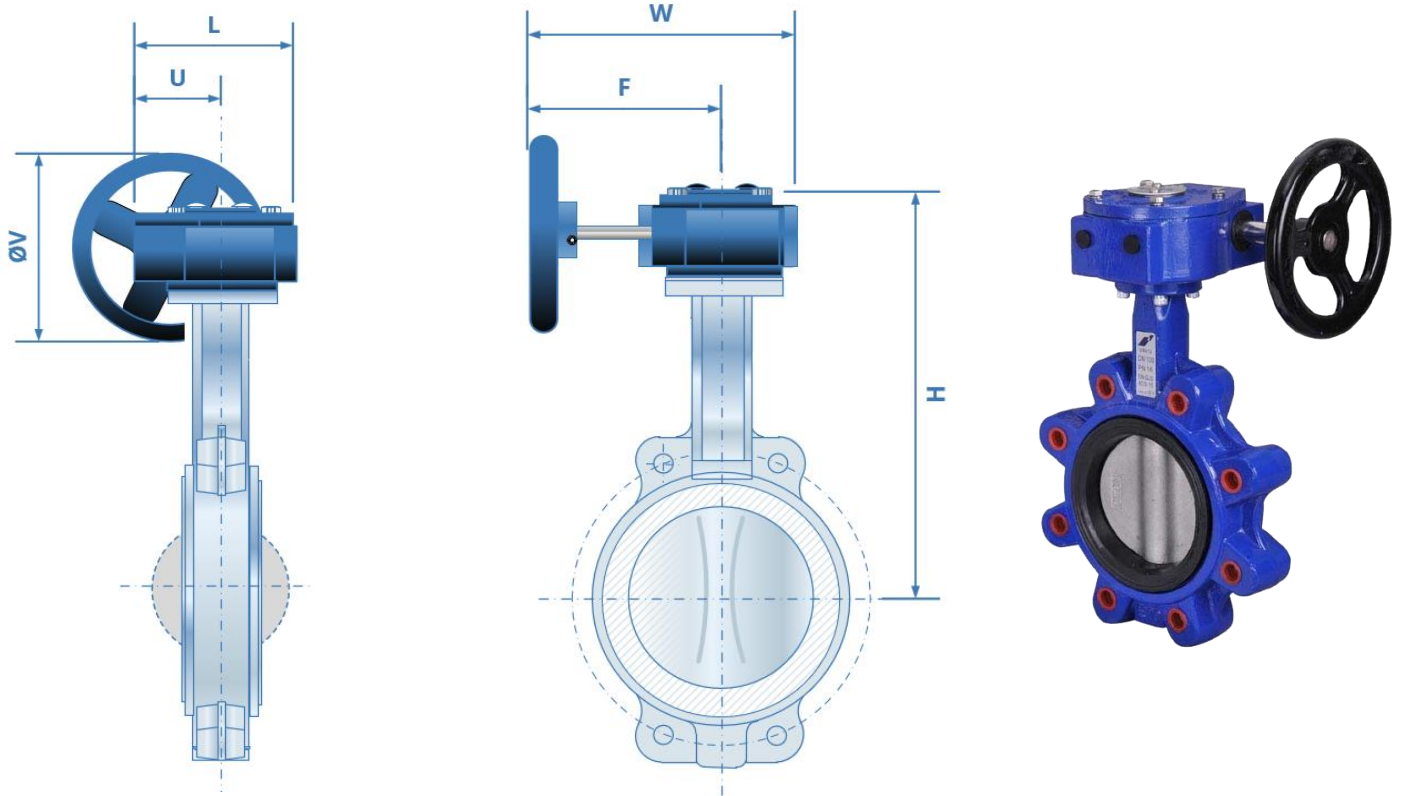

Dimensions

Size	L	U	H	W	F	V
1"	130	77	166	225	170	150
1 1/2"	130	77	178	225	170	150
2"	130	77	188	225	170	150
2 1/2"	130	77	198	225	170	150
3"	130	77	212	225	170	150
4"	130	77	232	225	170	150
5"	130	77	242	225	170	150
6"	130	77	262	225	170	150
8"	180	104	308	338	260	300
10"	205	124	346	345	260	300
12"	205	124	372	345	260	300
14"	205	124	415	345	260	300
16"	278	118	457	291	167	380
18"	278	118	519	291	167	380
20"	277	107	607	379	207	285
24"	323	131	693	428	256	385

Gearbox



These valves are suitable for many applications including heating (HVAC), water treatment and water distribution, industrial applications, agricultural and for compressed air, gas, oils and hydrocarbons.

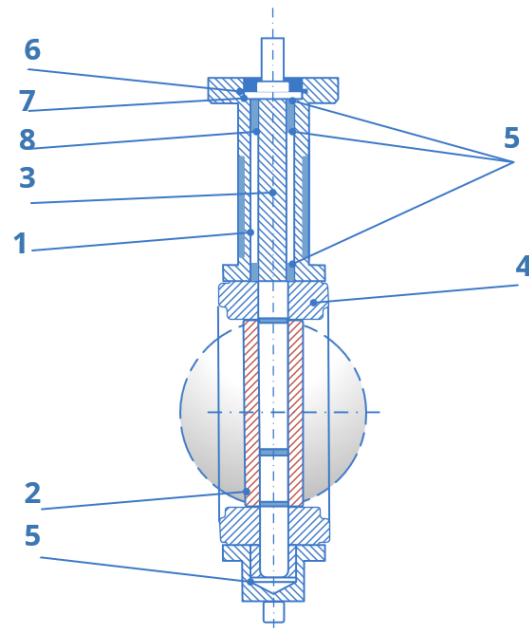

Material List

1	Body	Epoxy Coated Ductile Iron
2	Disc	Stainless Steel
3	Liner	EPDM, NBR, FKM, PTFE
4	Shaft	Stainless Steel
5	Bushing	PTFE
6	Washer	Galvanised Carbon Steel
7	Circlip ISO 3075	Steel
8	O-Ring	Viton
9	Lever	Aluminium up to 6" Ductile Iron 8" & Above
10	Bolts	Galvanised Carbon Steel

Pressure / Temperature

Pressure	1" - 16" - PN16
	18" - 24" - PN10
Temperature	EPDM -10°C to 120°C
	NBR -10°C to 80°C
	FKM (Viton) -10°C to 120°C
	PTFE -10°C to 120°C

All information is sourced from our manufacturer's data and is intended for guidance only - Valves Online can accept no liability for changes, omissions or errors.

Operating Torque (Nm)					
Size		3 Bar	6 Bar	10 Bar	16 Bar
1"	25	2.9	3.1	3.3	3.4
1 1/2"	40	7.8	8.4	8.8	9.2
2"	50	11.3	12	13	13
2 1/2"	65	17	18	20	21
3"	80	23	25	26	28
4"	100	33	36	40	44
5"	125	48	54	61	68
6"	150	68	78	88	99
8"	200	120	134	148	162
10"	250	189	212	264	257
12"	300	290	316	342	367
14"	350	298	347	396	550
16"	400	481	551	622	850
18"	450	930	980	1312	1543
20"	500	1250	1350	1848	2112
24"	550	2270	2500	3005	3535

Weight			
Size		Lever & Valve	Gearbox & Valve
1"	25	2.6	6.6
1 1/2"	40	2.3	6.3
2"	50	3.2	7.2
2 1/2"	65	4.1	8.1
3"	80	5.4	9.2
4"	100	6.7	10.5
5"	125	9.6	12.9
6"	150	10.8	14.1
8"	200	21.1	28.4
10"	250	32.7	42
12"	300		50.5
14"	350		79.3
16"	400		122.6
18"	450		154.8
20"	500		228.3
24"	550		308.6

KV Rates									
Opening	10°	20°	30°	40°	50°	60°	70°	80°	90°
1"									
1 1/2"	0.04	2.1	4.8	10	19	30	48	73	79
2"	0.05	2.6	6	13	23	38	60	91	99
2 1/2"	0.09	3.8	14	33	53	75	98	108	108
3"	0.17	7.8	16	34	60	100	158	237	261
4"	0.26	15	31	67	120	199	314	471	518
5"	0.43	25	53	115	205	339	535	803	883
6"	0.69	39	82	177	316	522	817	1241	1364
8"	2.6	52	142	250	450	713	1122	1723	2716
10"	2.6	130	276	599	1068	1768	2798	4196	4611
12"	3.5	202	427	926	1650	2730	4322	6483	7124
14"	5.2	292	617	1376	2384	3945	6243	9364	10291
16"	6.9	401	849	1839	3279	5425	8585	12878	14152
18"	9.5	531	1124	2437	4342	7185	11371	17057	18743
20"	12	683	1445	3133	5609	9238	14620	21930	24099
24"	19	1055	2234	4840	8626	14272	22587	33882	37232

Head loss Fluid: water (1m H₂O = 0,098bar) - Head loss with shutter fully opened

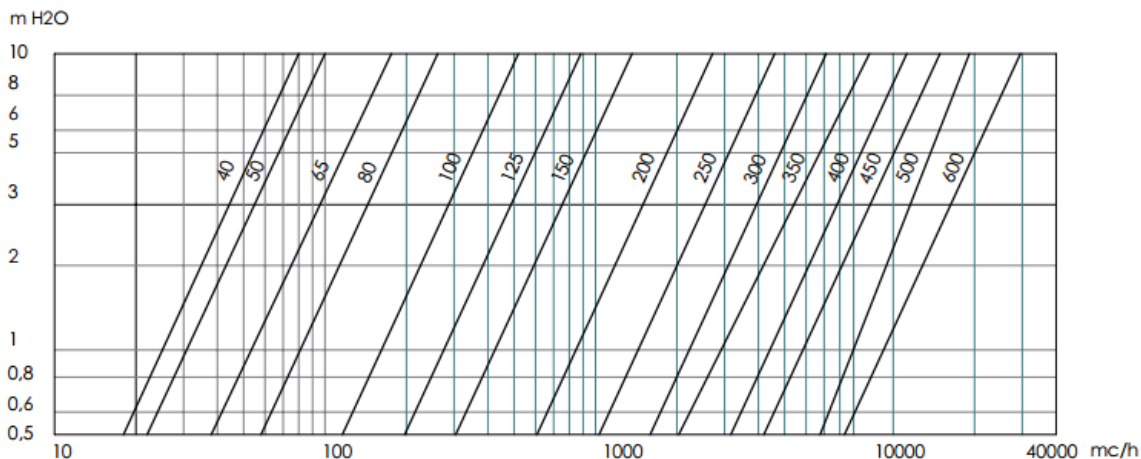

Flow rate / opening position chart Flow percentage on the flow at full opening under the same loss of head.

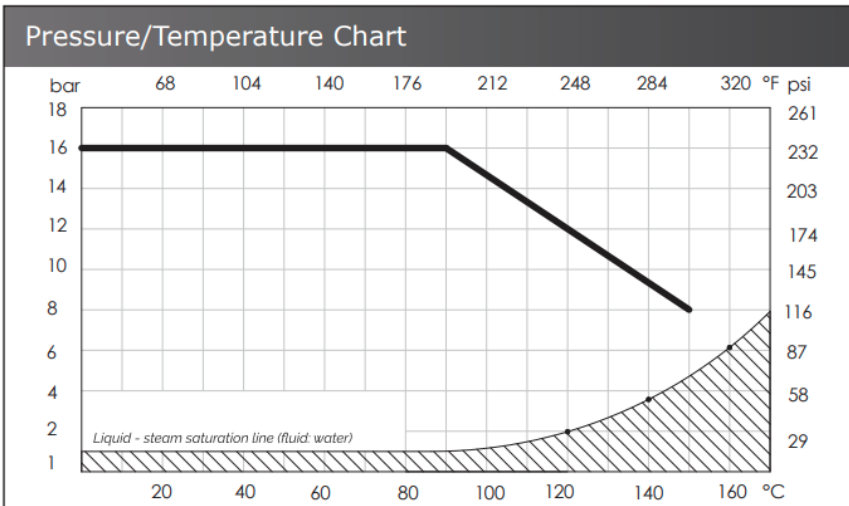
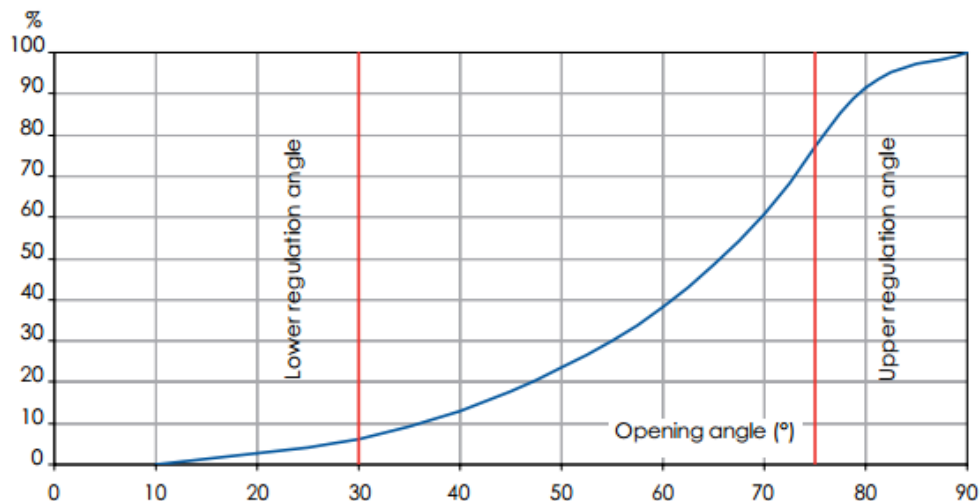

Note: Do not use when temperature and pressure are below the liquid-steam saturation line (hatched area)

All information is sourced from our manufacturer's data and is intended for guidance only - Valves Online can accept no liability for changes, omissions or errors.

INSTALLATION AND TRANSPORT

- Keep in dry and closed place.
- While stored, the disc must be partially open (Fig. 1).
- Avoid knocks, take special care to protect lever, hand wheel, gear boxes/actuators.
- Do not use lever or hand wheel to lift the valve.

MAINTENANCE

The valve does not require maintenance.

RECOMMENDATIONS

Before carrying out maintenance or dismantling the valve, be sure that the pipes, valves and liquids have cooled down, that the pressure has decreased and that the lines and pipes have been drained in case of toxic, corrosive, inflammable or caustic liquids.

Temperatures above 50°C and below 0°C might cause damage to people.

INSTALLATION

- Handle with care.
- Do not weld the flanges to the piping after installing the valve.
- Water hammers might cause damage and ruptures. Inclination, twisting and misalignments of the piping may subject the valve to stress, once installed. It is recommended that elastic joints be used in order to reduce these effects as much as possible. The disc must be partially open (Fig. 1).

FIG. 1

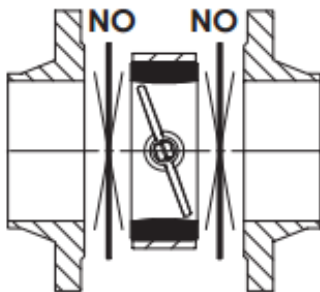
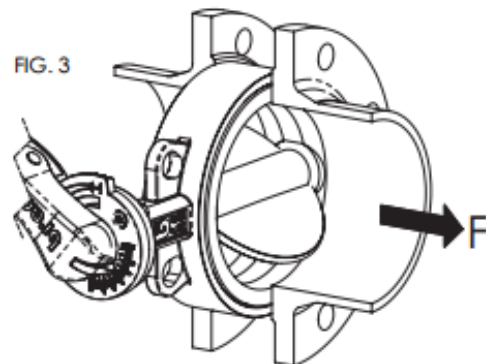

FIG. 2



FIG. 3



The stem has a machined notch N (Fig. 2), which indicates the position of the disc; consider this indication, in order to mount the levers and actuators correctly.

The mounting can be made with the stem axis in a horizontal or vertical position. In case the fluid contains suspended solid particles (for example, sand, impurities, etc.) or solid particles that may leave deposits, it is recommended that the valve be installed with its axis horizontal, and in such a way that the bottom end of the disc opens in the direction of flow, F. (Fig. 3)

The item L9 allows the dismantling of the pipes downstream, for pressures below 6 bar. For end of line installation:

- SERIES J9 (all pressures), series L9 (pressure > 6 bar): counter flange **MUST** be installed
- SERIES L9 (pressure < 6 bar): it is recommended that a counter flange be installed.

Verify maximum working pressure and limits of use under section "maximum pressure".

Place the valve between two flanges. While placing the valve, ensure there is sufficient space in order not to damage the rubber. Do not mount seals between valve and flanges (Fig. 1). Carefully clean the contact surface. Do not install the butterfly valve in direct contact with a rubber surface (for example, expansion joints); the best installation is when the rubber is in contact with metal (Fig. 4).

In order to achieve correct working, the internal diameter of the pipe must be greater than the value indicated in the chart. Do not weld the flanges to the tube if the valve has already been installed. It is recommended that the flanges listed in the chart be used. As far as possible, avoid flat flanges for welding (EN 1092 01 type); if these flanges are used, ensure perfect centring between the flange and valve, and be sure to weld exactly edgewise to the flange. Do not let protrusions or sharp edges on the piping cause damage to the rubber surface of the valve (Fig. 5).

FIG. 4

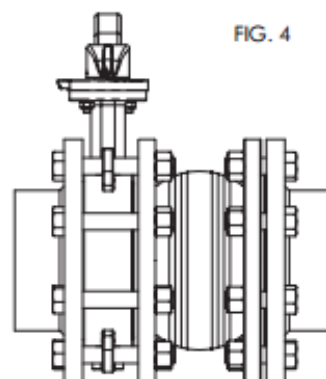
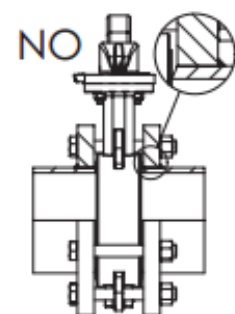

FIG. 5



Centre the valve on holes while using wafer type valves.
Tighten the bolts crosswise and progressively, in order to distribute the pressure equally before the body and flanges come into contact with each other. (Fig. 6)

With regard to the Lug version, check that the screws are the correct length, in order to allow complete compression of the lining rubber.

Turbulences of the fluid might increase erosion and reduce the life-cycle of the valve. Install the valve at a distance of at least 1 x DN upstream, and at a distance of 2-3 x DN downstream, away from fittings or bends.

In the open position, the valve is larger than the nominal Face to Face value.

Check that no other components of the piping interfere or create damage or malfunction (Fig. 7A).

If they do, a spacer should be inserted for the valve to operate correctly (Fig. 7B).

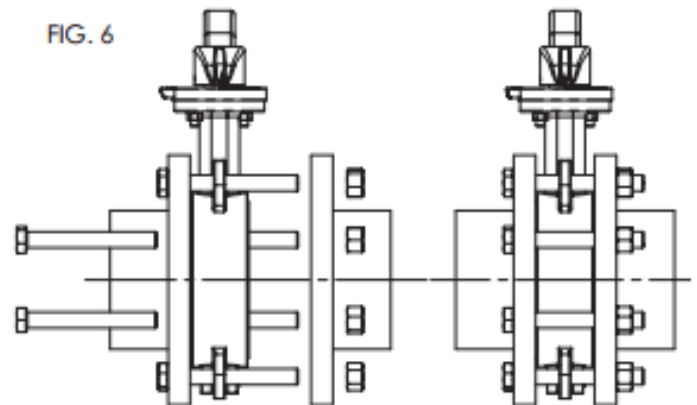

FIG. 7A

NON OK

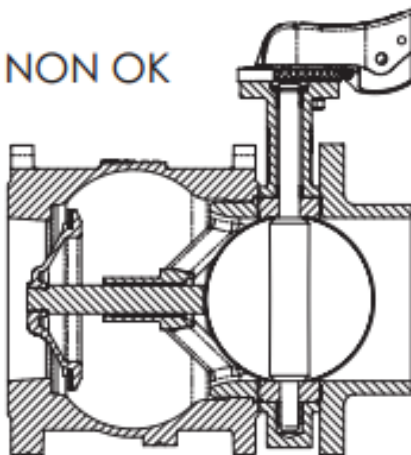
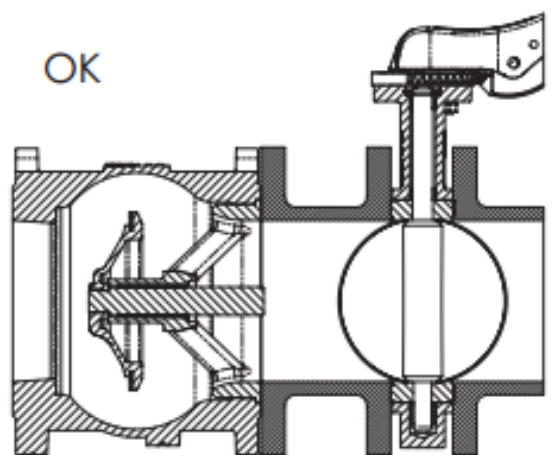

FIG. 7B

OK



All information is sourced from our manufacturer's data and is intended for guidance only - Valves Online can accept no liability for changes, omissions or errors.

